

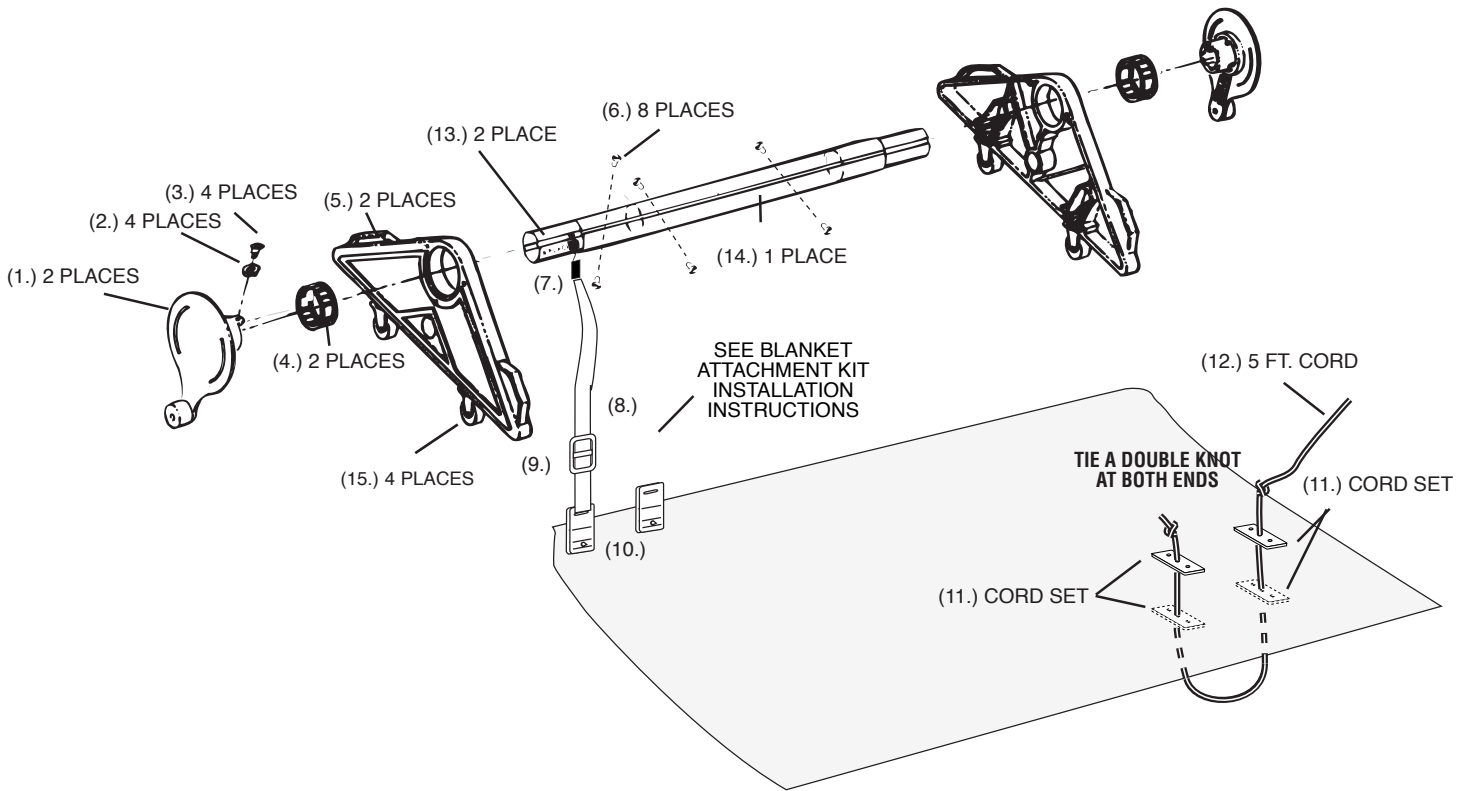

FREEDOM SERIES M400 REEL SYSTEM

Assembly and Operation Instructions

For Solar Covers up to 20' x 45' (Max 12 Mil Thickness)



TOOLS REQUIRED

Power Drill
Drill bits for cutting metal – 1/2" & 13/64" sizes

Hex Socket Wrench w/ 7/16" hex socket
Phillips Screwdriver

PARTS LIST

PARTS DESCRIPTION	PART#	QTY	PARTS DESCRIPTION	PART#	QTY
1. Handwheel w/handle	523	2	9. Strap Buckle	800	8
2. 3/4" Nylon Washers	450	4	10. Quick Clip Cover Plate	600	8
3. 1-1/4" Phillips Shoulder Bolt	415	4	11. Cord plate	610	2
4. Bearing Race Assembly	615	2	12. 5' Return Cord	840	1
5. Main Frame	504	2	13. 8'6" Aluminium Tube (Inner)	216A	2
6. Neoprene Tube Insert	475	8	14. 8'6" Aluminium Tube (Outer)	217A	1
7. Velcro Hook Piece	880	8	15. Metal Casters (Wheels)	468	4
8. 6' Blue Strap	890	8			

INITIAL PREPARATIONS

- Prior to assembly, select the most suitable location for the reel, normally 2 ft. from either end of the pool. However, on irregular pools, a location closer to the center of the pool may be preferred and at the pools maximum width. Other considerations are obstructions (diving boards, handrails, etc). When in doubt, consult your dealer or call Odyssey for an evaluation of your reel placement.
- BLANKET PREPARATION:** In order for your solar blanket to roll up neatly on the solar reel, allow the blanket to relax on the pool for a day or two and let the heat of the sun iron out the folds and creases of the blanket.

LAZY "L"

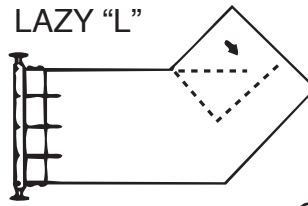

OVAL WITH EXTENSION

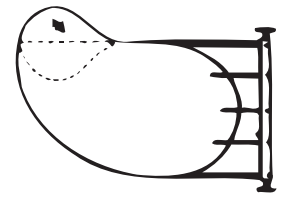

RECTANGULAR

ASSEMBLY INSTRUCTIONS

- Remove all Tube Sections and place on a flat ground as in (FIG. 1). SECTION 1 IS STORED INSIDE OF SECTION 2. Slide sections 1 and 3 out to the desired total tube length. (Usually pool width plus two feet). Refer to Table #1 and (FIG. 1).

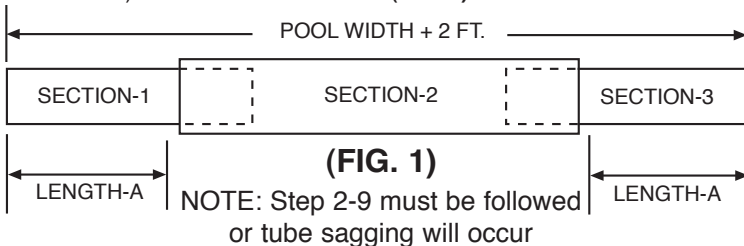

- To attach the **LEFT SIDE** of section 1 & 2 tubes. Using (FIG. 2), with a power drill and a sharp 1/2" bit, Drill a hole 3" from the **left end** of the **section 2** tube and in the **center** of the groove cut in the tube. Drill through both **section 1** and **section 2**. (Refer to Step 2)
- Place neoprene tube insert into the hole. Using a hex socket wrench and a 7/16" socket, rotate hex head **two (2) complete turns and stop**. (Refer to Step 2)
- Rotate tube sections 90° and drill a hole 14" from the left end of the tube **section 2**. (Refer to Step 3) Repeat all instructions in #3 above.
- Rotate tube sections 90° and drill a hole 3" from the **left end** of the tube **section 2**. (Refer to Step 4) Repeat all instructions in #3 above.
- Rotate tube sections 90° and drill a hole 14" from the **left end** of the tube **section 2**. (Refer to Step 5) Repeat all instructions in #3 above.
- Rotate tube sections 90°. Using a hex socket wrench and a 7/16" socket, to tighten each hex head an **additional** two (2) complete turns.
- Continue to rotate tubes and tighten hex heads until all are tight and neoprene insert body mushrooms. **Do not overtighten.** (SEE FIG. 3)
- To attach the **RIGHT SIDE** of section 2 & 3 tubes. Repeat instructions #2 thru #8 above, but taking all hole measurements from the **RIGHT END** of tube **section 2**.
- ATTACH RACE AND HANDLE TO TUBE--Place the main frames in contact with the pool deck, insert tube through the center opening. Refer to (FIG. 4)
- Slide bearing race assembly onto each handwheel and seat in main frame bushing – center opening. Refer to (Step 7).

TABLE #1

POOL WIDTH FEET	TOTAL TUBE LENGTH FEET	LENGTH A FEET
14	16'	4
16	18'	5
18	20'	6
20	22'	7

NOTE: Under no circumstances should the system be operated if Length A exceeds 9 ft. Tubes may be cut in size in order to accommodate smaller pool widths. It is recommended to cut an equal amount off sections 1 & 3.

(FIG. 2)

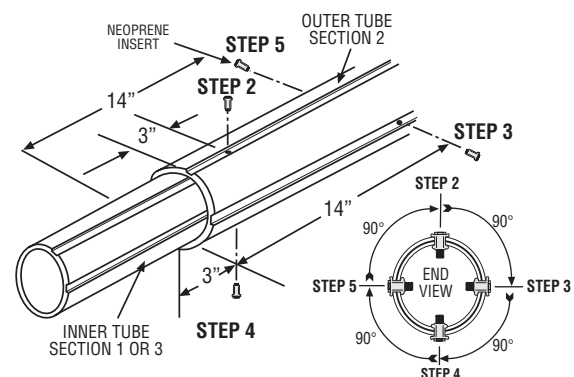

(FIG. 3)

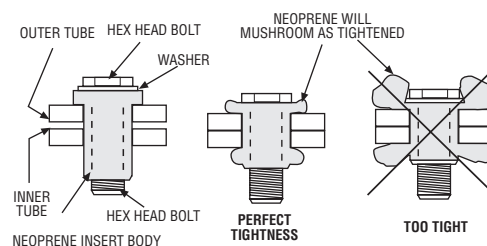

(FIG. 4)

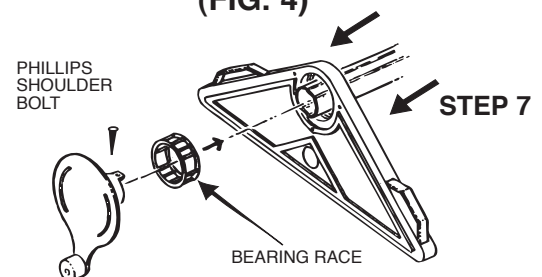

ASSEMBLY INSTRUCTIONS (Cont.)

12. Rotate each hand wheel until the tab for the screw is at the top position as shown in **STEP 8**. Align the keys in the handwheel collar with the corresponding key ways in the handle and rotate them to make certain that the aluminum tube is making contact with the back wall of each handle.
13. Using the pre-drilled holes in the hand wheel collar as a guide, drill a 13/64" hole thru each side of the tube. Insert 1-1/4" long Phillips shoulder bolt thru the nylon washer and into the drilled holes in the aluminum tube and screw until tight. Repeat these instructions to install hand wheel to main frame at other end. **Refer to Step 8.**

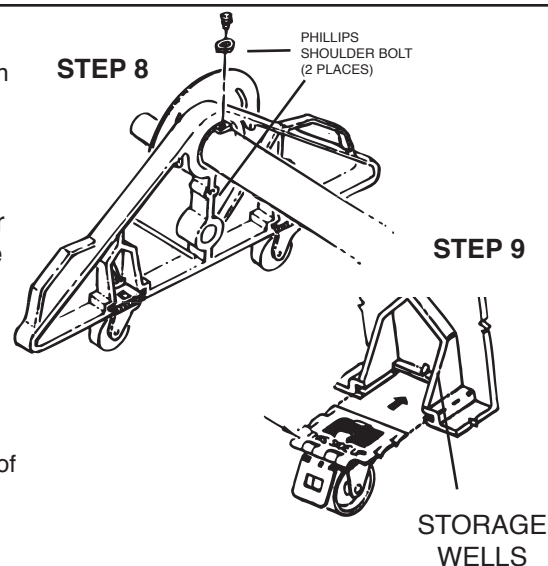
**MAGNETIC CASTER INSTALLATION**

14. Orient the caster assembly as in (**Step 9**). Magnetic plate should be on the top and is marked "THIS SIDE UP". Grip top holding plate and slide magnetic plate into the slot on the back of the main frame. Using a small hammer, tap the back of the magnetic plate adjacent to the hinge, alternating right and left side, until the front of the plate is abutting the main frame and the caster assembly is seated tightly into slot. Repeat steps for remaining 3 casters. Casters should always be seated in storage wells until you wish to move the system.

ATTACHING THE COVER FOR IN-GROUND POOLS

15. The reel system should be positioned at the end of the pool, perpendicular to the center line of the pool (**SEE FIG. 1**). The cover should be on the pool and properly trimmed.
16. Starting at a point approximately 3" from one edge of the end of the cover to which the reel will be connected, attach a plastic cover clip (**SEE FIG. 2**) to the cover. The sharp pointed post on the clip will pierce the cover (or use a knife or other sharp tool for ease of installation). Continue across the edge of the cover attaching the remaining seven clips, evenly spaced. The last clip should be positioned approximately 3" from the opposite edge of the blanket (**SEE FIG. 3**).
17. Assembly of strap and buckle: With the ridged crossbar of the buckle facing up, slide the buckle onto the strap from the end opposite the Velcro end. Move the buckle at least 24" up from the end of the strap (**SEE FIG. 4**). Feed the end of the strap through the slot on the plastic clip then thread the strap end back through the buckle as indicated by the dotted lines in the diagram. Repeat the process at each clip position (**SEE FIG. 5**).
18. Position the Velcro end of the strap as straight as possible over the tube of the reel system. Place a Velcro tab on the tube at the Velcro strap end by removing the protective backing. The tube must be dry and clean where the Velcro tab is being placed (**SEE FIG. 6**). Attach the Velcro end of the strap to the Velcro tab. Repeat this process in a straight line along the tube for each of the seven remaining straps. Using the buckles, adjust each strap so that each has equal tension on the cover. This is necessary for proper roll-up alignment. **The extra length should wrap around the tube to facilitate pulling the blanket off the pool and on to the tube. The Velcro tabs alone are not strong enough to pull the blanket up off the pool.**

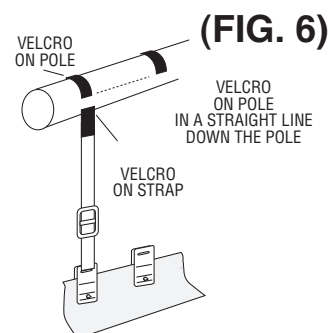
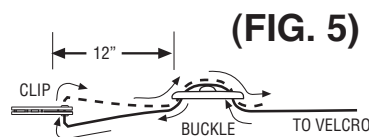
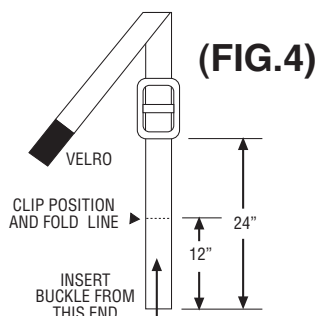
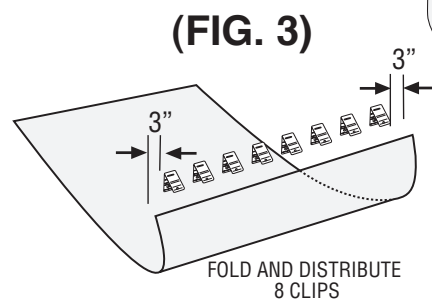
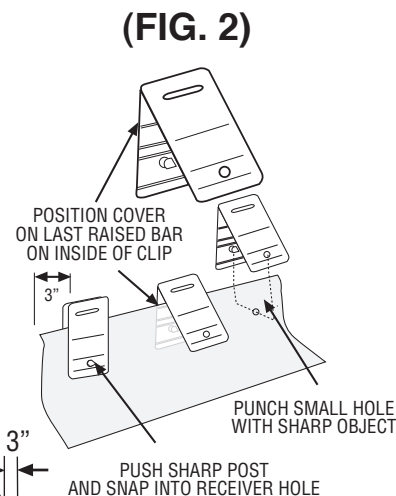
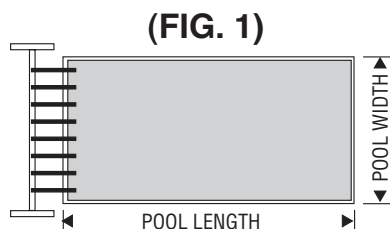

19. For ease of re-covering your pool after use, install the return cord provided at the opposite end of the pool cover using the white cord and two sets of male/female cord plates. Locate the plates about 3" apart and at least 6" from the edge of the cover (**FIG. 7**). To install plates, use the plate with three holes as a guide to punch three holes through the cover. Snap the posts on the male plate through the two holes on the female plate with the cover sandwiched between the two plates (**FIG. 8**). Thread the return cord through the top center hole of plate #1 and plate #2 as shown in the diagram and then tie a double knot at both ends (**FIG. 7**).

OPERATING INSTRUCTIONS

20. Place the reel system so that it straddles the pool, and is 2 ft from end of pool as in (**FIG. 10**). More distance may be required for irregular pools. If your pool IS NOT rectangular shape, merely fold the cover in the irregular areas back on itself so that the entire pool cover can pass between the two end main frames of the system.
21. Rotate handwheel slowly. The straps will move the cover away from possible damage on the coping and fold back into itself. Continued rotation of the handwheel will transport the cover underneath the tube and then up, over and onto the tube (**SEE FIG 9**). In the unlikely event that the Main frame "creeps" during this operation, use free hand to hold main Frame until the entire cover is removed from pool. Attempt to keep seams straight and avoid misalignment.
22. If system has retrieved the cover with ease, you are operating the system correctly. It is suggested that you mark the position of the Main frames during operation on the pool decking for future use of the system.
23. **AVAILABLE OPTION:** For portability, this system is designed for the optional **Magnetic Caster Assembly Part No. 468 (4 required)**. See your Odyssey Dealer for details.
MANUFACTURER IS NOT RESPONSIBLE FOR DAMAGE OR ACCIDENT RESULTING FROM IMPROPER OR UNSAFE STORAGE OR MOVEMENT

PLACING THE COVER ON THE POOL

24. Roll the reel system to a straddling position 2' from the end of the pool, onto the deck marking suggested in (**FIG. 10**), lock casters up (if installed) prior to unrolling cover.
25. Hold white return cord and walk down the length of the pool, allowing the system to "free wheel" the cover back onto the pool surface. Replace folded-back cover into irregularly shaped areas.
26. Your cover is now installed and operational. If you wish to remove the reel system from the pool while the cover is on the pool, detach the straps using the lift-off velcro tabs (**SEE FIG. 10**), and roll empty system to storage area.

SOME HELPFUL HINTS

1. Make sure the cover is not dragging against the side of the pool coping.
2. If tube is sagging: refer to assembly instruction on drilling tubing and tighten neoprene inserts.
3. If tubes discolors, they can be restored using Flitz metal polish available at hardware/marine stores.
4. Place a white protective cover over blanket and secure to protect blanket from the sun when rolled up.
5. Do not use lubricants on any plastic parts.
6. Remove handwheels at the beginning of each season, or every 12 months. Clean yoke bushing, bearing race, and end cap with warm soapy water. Rinse, dry and reassemble.
7. Always store the reel with an eye for safety.



FIG. 9

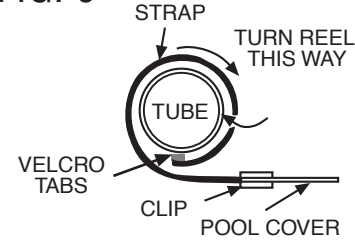
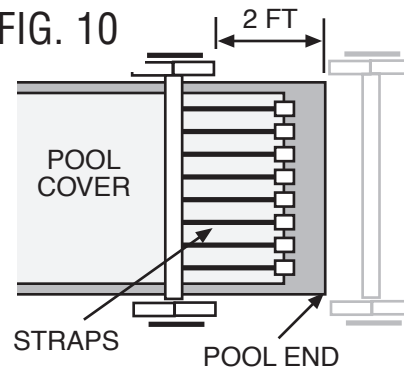

FIG. 10



LIMITED WARRANTY

ODYSSEY warrants the reel system to be free of workmanship/material defects for a period of three (3) years from the date of purchase. Any claims must be supported by invoice/proof of purchase.

EXCLUDED FROM THIS WARRANTY ARE ALL CONSUMABLES: straps, cord, velcro, plastic plates and clips.

ODYSSEY WILL not be liable for any incidental or consequential damages resulting from any defects in workmanship or material, nor for personal injury resulting from improper placement of reel system when not in use.

ODYSSEY SYSTEMS

220 South Ola Vista, Suite C, San Clemente, CA 92672
 (949) 498-9454 • Fax (949) 361-0608
www.odysseysystems.com